

# **IST8812**

# **Low-Power Linear Hall**

# **Analog Sensor**

# **Datasheet**

**Table of Contents**

- 1. GENERAL DESCRIPTION ..... 3**
- 2. BLOCK DIAGRAM, PACKAGE DIMENSIONS, MAGNETIC FIELD DIRECTION, PIN CONFIGURATIONS, AND APPLICATION CIRCUIT ..... 4**
  - 2.1. Block Diagram.....4
  - 2.2. Package Dimensions.....5
  - 2.3. Location of Hall Sensing Elements .....6
  - 2.4. Marking.....6
  - 2.5. Magnetic Field Direction .....6
  - 2.6. Pin Configurations and Application Circuit.....7
- 3. ELECTRICAL SPECIFICATIONS ..... 8**
  - 3.1. Absolute Maximum Ratings.....8
  - 3.2. Recommended Operating Conditions .....8
  - 3.3. Electrical Specifications.....8
  - 3.4. Magnetic Specifications .....9
- 4. FUNCTIONAL DESCRIPTION ..... 11**
- 5. ORDERING INFORMATION ..... 11**
- 6. PACKING INFORMATION ..... 12**
- 7. LEGAL DISCLAIMER ..... 12**
  - 7.1. Warranty and Liability Disclaimer ..... 12
  - 7.2. Application Disclaimer ..... 12
  - 7.3. Disclaimer Regarding Changes ..... 13

## 1. General Description

The IST8812 series are linear Hall-effect sensors that provide an analog output voltage proportional to the applied magnetic field. The devices operate from a supply voltage of 1.7 V to 5.5 V, with a quiescent output voltage of approximately 50% of VDD.

Each IST8812 integrates a Hall sensing element, a linear amplifier, and a CMOS output stage on a single chip. Sensitivity options range from 1.5 mV/Gauss to 5.0 mV/Gauss at a 5 V supply. The devices feature low output noise and a typical null voltage offset of less than 1% of VDD. The IST8812 series are optimized for low power consumption, with a typical current consumption of 2 mA at 5 V.

### Features

- Supply voltage (VDD): 1.7 V to 5.5 V
- Typical current consumption: 2 mA at 5 V
- Sensitivity options:
  - **IST8812-A:** 2.5 mV/Gauss (Typ.)
  - **IST8812-B:** 1.5 mV/Gauss (Typ.)
  - **IST8812-C:** 5.0 mV/Gauss (Typ.)
- Bandwidth: 30 kHz (Typ.)
- Quiescent output voltage: ~50% of VDD
- Low output noise: typically 6 mVpp at 5 V with 2.5 mV/G sensitivity
- Null voltage offset: typically less than 1% of VDD
- Operating temperature range: -40°C to 85°C
- RoHS compliant

### Applications

- Precision position detection
- Joystick control
- AR/VR systems
- Gamepad input sensing
- Liquid level detection

## 2. Block Diagram, Package Dimensions, Magnetic Field Direction, Pin Configurations, and Application Circuit

### 2.1. Block Diagram

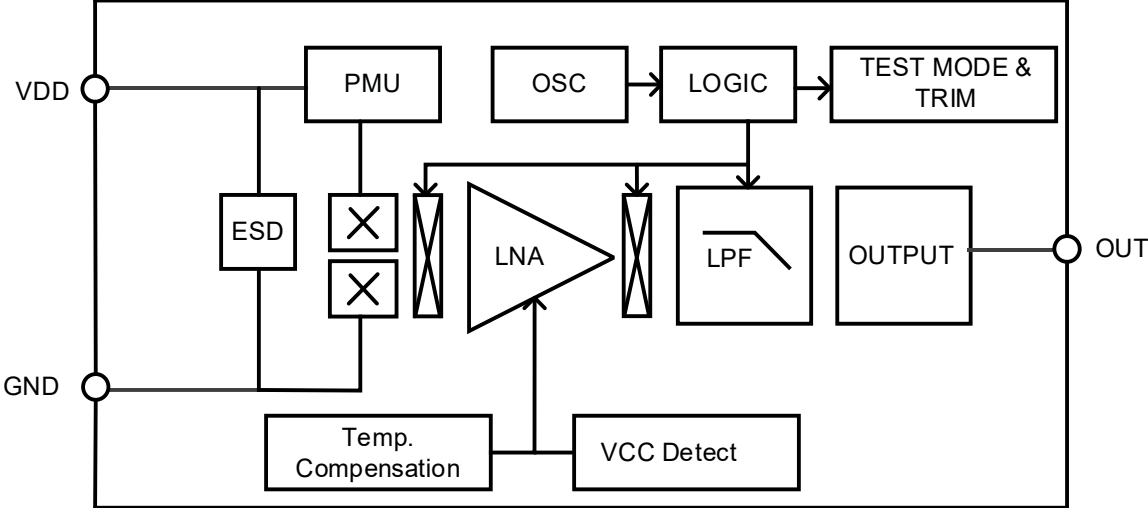
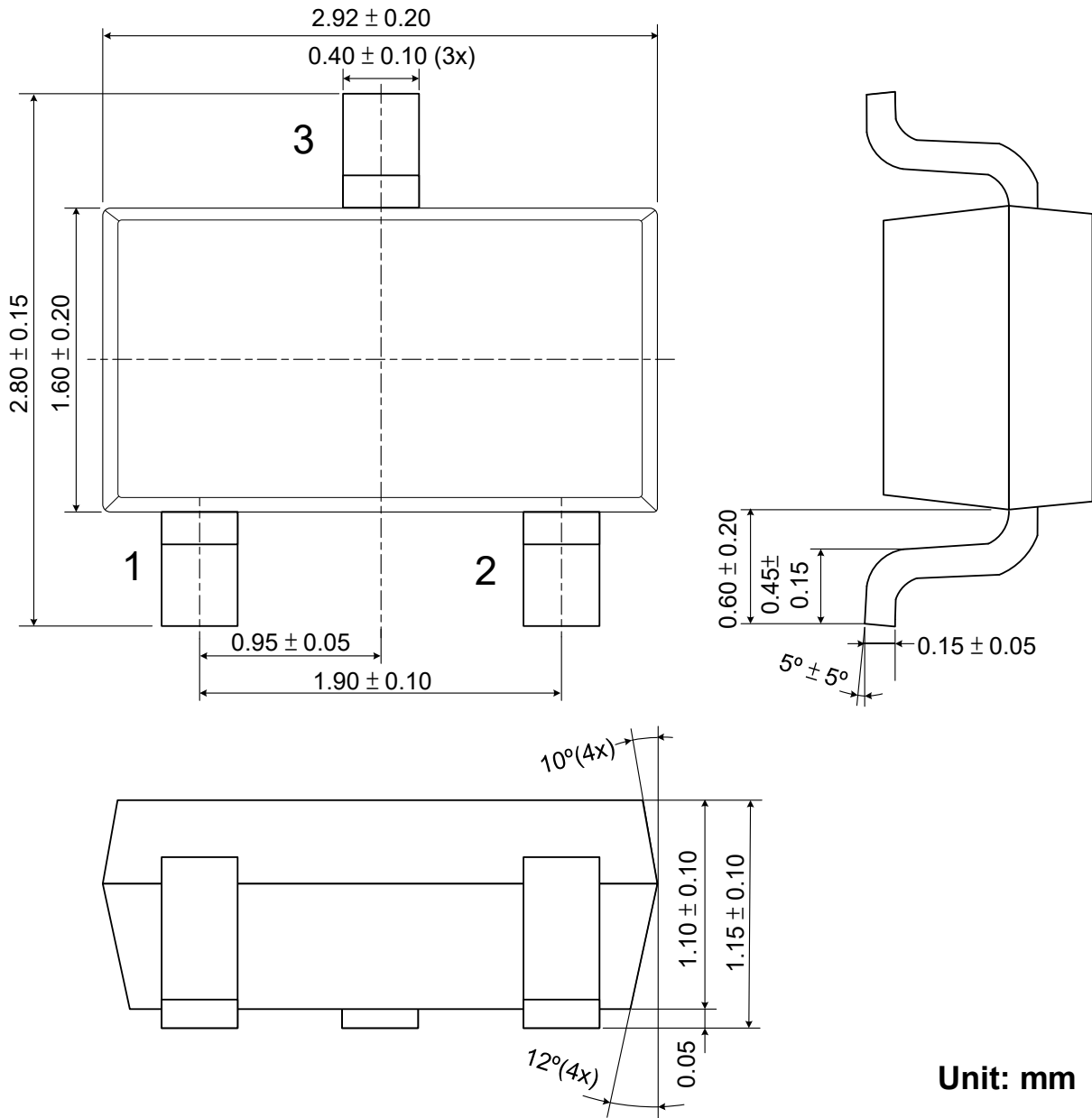

Figure 1. Block Diagram

2.2. Package Dimensions



Unit: mm

Figure 2. SOT23-3L Package Dimensions

### 2.3. Location of Hall Sensing Elements

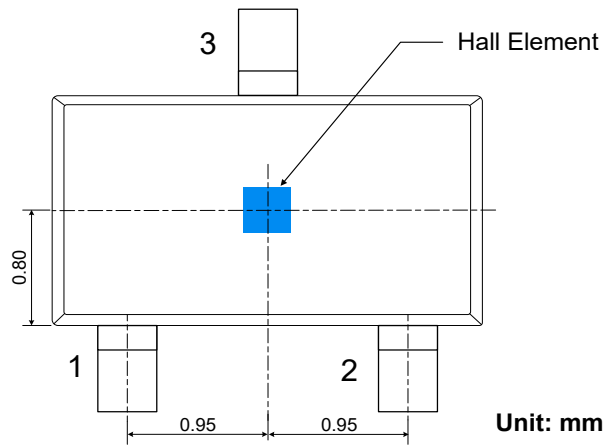

Figure 3. Hall Element Locations

### 2.4. Marking

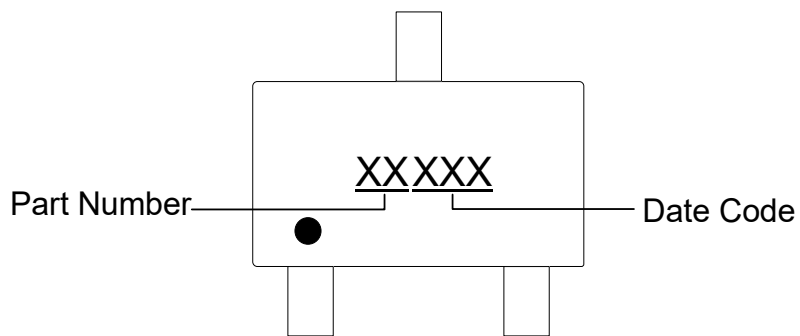

Figure 4. Marking

### 2.5. Magnetic Field Direction

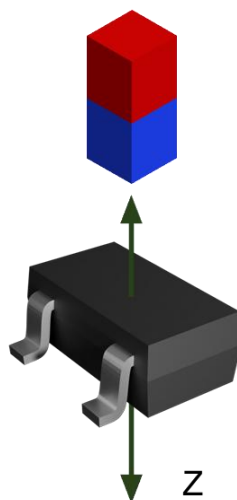

Figure 5. Magnetic Field Direction

## 2.6. Pin Configurations and Application Circuit

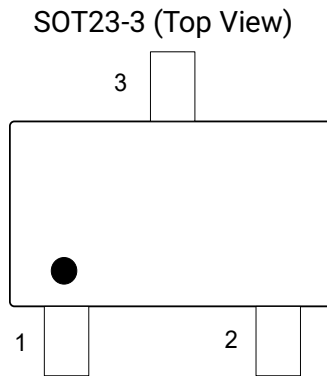

Figure 6. Pin Assignments

Pin Name	Pin No.	I/O	Pin Function
VDD	1	I	Power Supply
OUT	2	O	Analog Output
GND	3	I	Ground

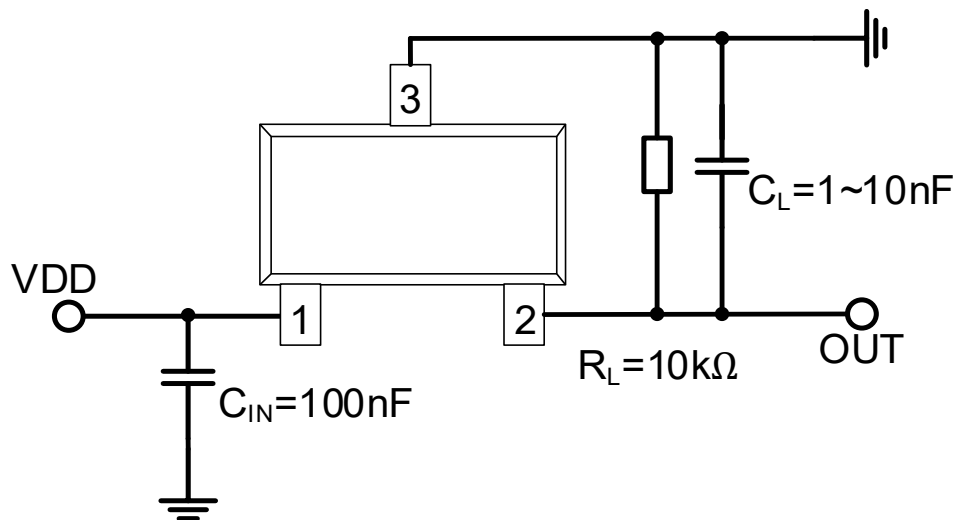

Figure 7. Application Circuit

**Note:**  $C_L$  and  $R_L$  are optional and may be adjusted depending on the system requirements.

## 3. Electrical Specifications

### 3.1. Absolute Maximum Ratings

Parameter	Symbol	Limits	Unit
VDD to GND	V <sub>DD</sub>	-0.3 to 6	V
Output to GND	V <sub>OUTPUT</sub>	-0.3 to VDD	V
Output Current	I <sub>OUT</sub>	20	mA
Maximum Power Dissipation	PD	255	°C/W
Storage Temperature	T <sub>S</sub>	-50 to 150	°C
Maximum Junction Temperature	T <sub>J</sub>	150	°C
Electrostatic Discharge Voltage* <sup>1</sup>	VESD_HBM	2000	V
Lead Temperature (Soldering, 10 Sec.)	T <sub>LT</sub>	260	°C

Note: If the device is used in conditions exceeding these limits, it may malfunction permanently. Performance cannot be assured when these limits are exceeded.

1. Human Body Model (HBM)

### 3.2. Recommended Operating Conditions

Symbol	Parameter	MIN	Max	Unit
V <sub>DD</sub>	Supply Voltage	1.7	5.5	V
T <sub>A</sub>	Operating Temperature Range	-40	85	°C
I <sub>OUTPUT</sub>	Output current	-1150	1150	µA
R <sub>L</sub>	Output Load Resistance	4.7	-	kΩ
C <sub>L</sub>	Load capacitance on OUT pin	-	10	nF

### 3.3. Electrical Specifications

(Unless otherwise stated, VDD = 1.7 – 5.5V, T<sub>A</sub> = 25°C)

Parameter	Symbol	Conditions	Min.	Typ.	Max.	Unit
Supply Current	I <sub>DD</sub>	V <sub>DD</sub> = 5 V	-	2	-	mA
Quiescent Output Voltage	VOQ	B = 0 G	-	50	-	%VDD
Power-On Time	TPO	T <sub>A</sub> = 25°C	-	28	-	µs
Bandwidth	BW	-3 dB, CL = 1 nF	-	30	-	kHz
DC Output Resistance	R <sub>OUT</sub>	B = 0 G	-	0.5	2	Ω
Magnetic Response Time	t <sub>RESPONSE</sub> <sup>1</sup>	BW = 30 kHz	-	16	-	µs

**Note 1:** t<sub>RESPONSE</sub> is the time required for the output to respond to a change in the magnetic field. Output data should be read after t<sub>RESPONSE</sub> to ensure measurement accuracy.

## 3.4. Magnetic Specifications

(Unless otherwise stated,  $T_A = 25^\circ\text{C}$ )

Parameter		Symbol	Conditions	Min.	Typ.	Max.	Unit
Quiescent Voltage Offset		VOE	B = 0 G VDD = 5 V $T_A = 25^\circ\text{C}$	2.475	2.5	2.525	V
Sensitivity	IST8812-A	Sens	VDD = 5 V	2.388	2.5	2.613	mV/G
	IST8812-B			1.433	1.5	1.568	mV/G
	IST8812-C			4.775	5	5.225	mV/G
Linear Magnetic Sensing Range	IST8812-A	$B_L$	VDD = 5 V	-	$\pm 960$	-	G
	IST8812-B			-	$\pm 1600$	-	
	IST8812-C			-	$\pm 480$	-	
Linear Output Voltage Range		$V_L$	$T_A = 25^\circ\text{C}$	0.1	-	VDD - 0.1	V
Quiescent Voltage Temperature Drift		VOQ_ΔT	$T_A = -40 - 85^\circ\text{C}$	-	0.4	$\pm 1.5$	%VOQ_2 5°C
Sensitivity Temperature Coefficient		Sens_ΔT	$T_A = -40 - 85^\circ\text{C}$	-	$\pm 3.6$	$\pm 6$	%SENS_ 25°C
Nonlinearity Error		$E_{LIN}$		-	$\pm 0.3$	$\pm 1$	%
Quiescent Voltage Ratiometry Error		VOQ_RE	VDD = 4.5 – 5.5 V $T_A = 25^\circ\text{C}$	-	$\pm 0.7$		%
Sensitivity Ratiometry Error		Sens_RE	VDD = 4.5 – 5.5 V $T_A = 25^\circ\text{C}$	-	0.4	$\pm 1$	%
Input-Referred RMS Noise Density	IST8812-A	BND	$C_{load} = 1\text{ nF}$ $C_{in} = 100\text{ nF}$ BW = 30 kHz VDD = 5V	-	0.909	-	mVRMS
	IST8812-B			-	0.606	-	
	IST8812-C			-	1.5	-	
Input-Referred Peak-to-Peak Noise	IST8812-A	BN	BND $\times 6.6 \times \sqrt{BW}$ $C_{load} = 1\text{ nF}$ $C_{in} = 100\text{ nF}$ VDD = 5 V	-	6	-	mVpp
	IST8812-B			-	4	-	
	IST8812-C			-	9.9	-	

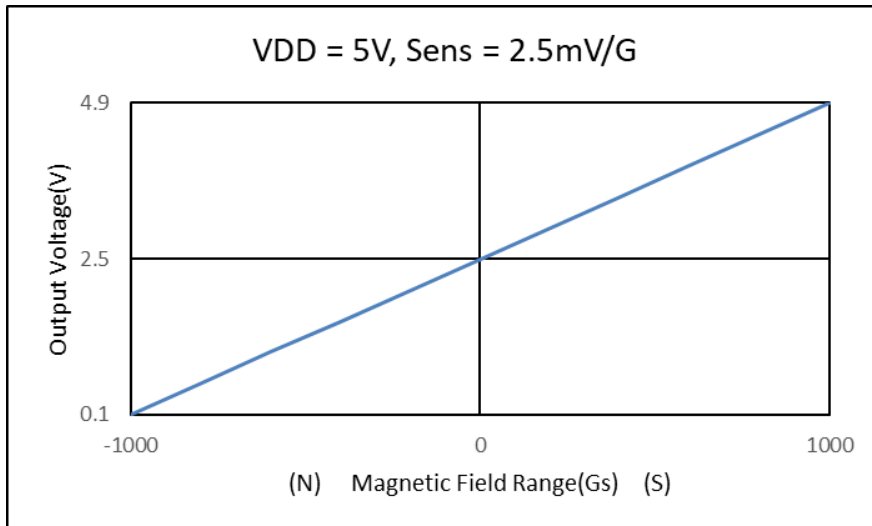

Figure 8. Output Voltage vs. Magnetic Field – VDD = 5 V, Sensitivity = 2.5 mV/G (IST8812-A)

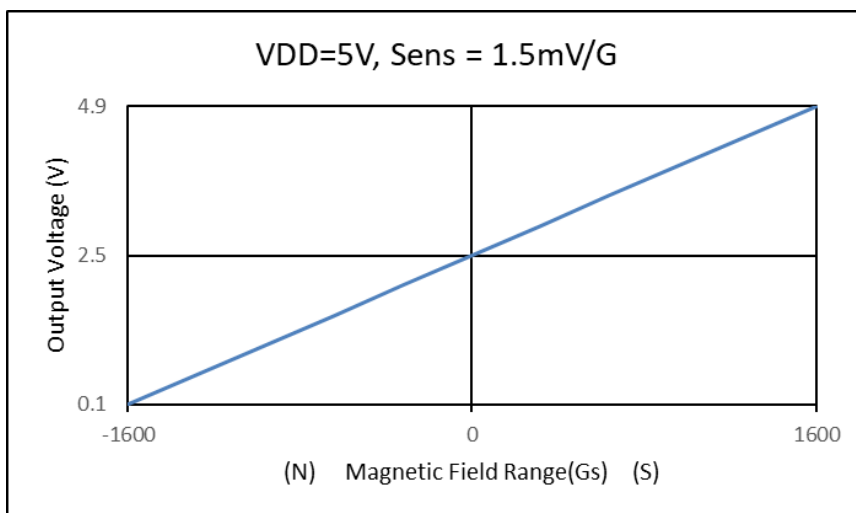

Figure 9. Output Voltage vs. Magnetic Field – VDD = 5 V, Sensitivity = 1.5 mV/G (IST8812-B)

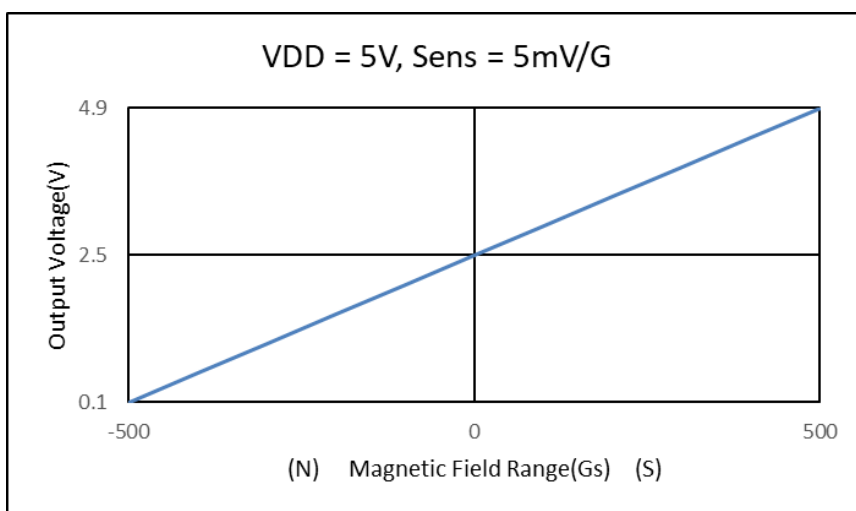

Figure 10. Output Voltage vs. Magnetic Field – VDD = 5 V, Sensitivity = 5 mV/G (IST8812-C)

## 4. Functional Description

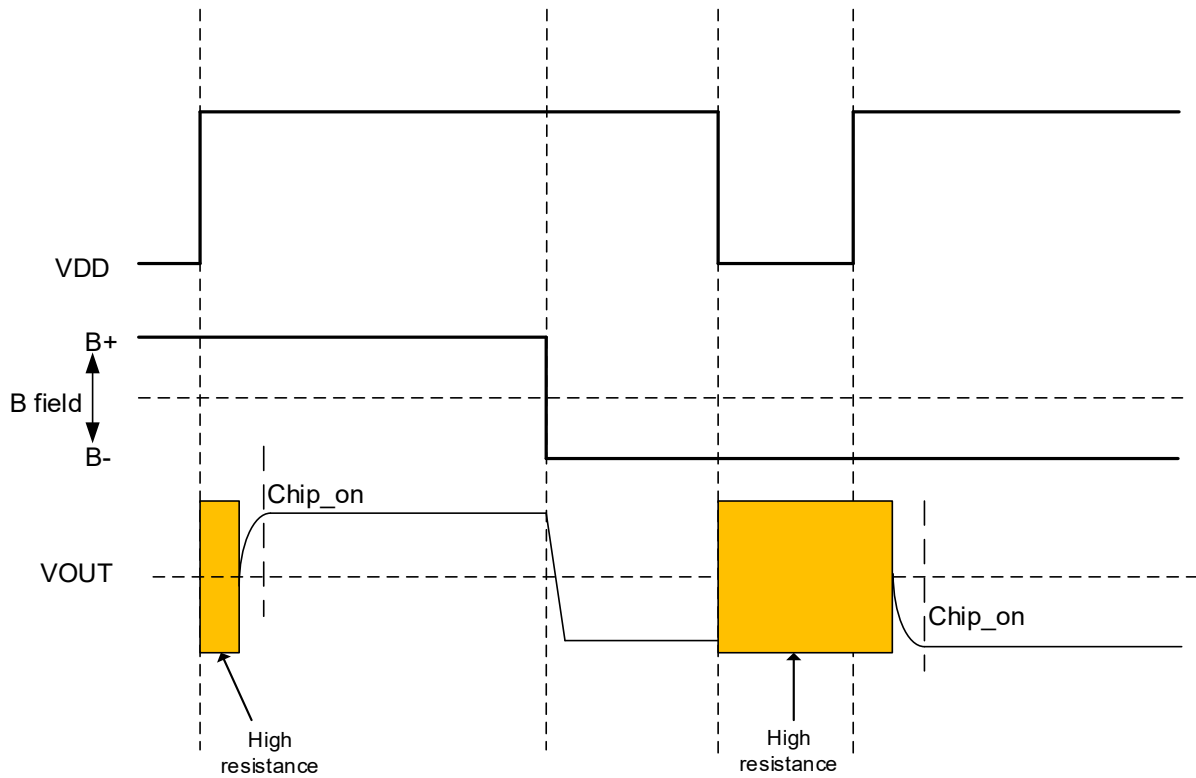

Figure 11. Functional Timing Diagram

**Note:** When  $B \neq 0\text{ G}$ ,  $Chip\_on = TPO + t_{RESPONSE}$ ,  
 When  $B = 0\text{ G}$ ,  $Chip\_on = TPO$ .

## 5. Ordering Information

Part Number	Sensitivity (Typ.)	BW	Package Type	Package Qty	Temperature	Lead
IST8812-A	2.5 mV/G @ 5 V	30 kHz	SOT23-3	3000pcs/Reel	-40 – 85°C	Cu
IST8812-B	1.5 mV/G @ 5 V	30 kHz	SOT23-3	3000pcs/Reel	-40 – 85°C	Cu
IST8812-C	5 mV/G @ 5 V	30 kHz	SOT23-3	3000pcs/Reel	-40 – 85°C	Cu

## 6. Packing Information

### REEL DIMENSIONS

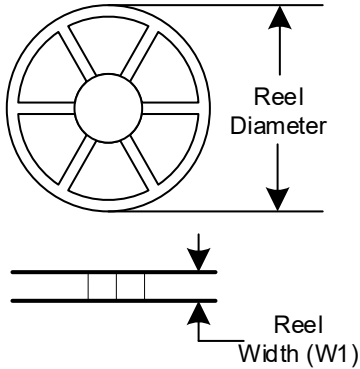

### TAPE DIMENSIONS

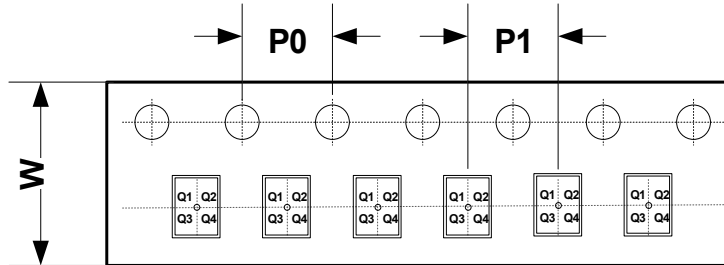

Package Type	Carrier Width(W)	Pitch(P0)	Pitch(P1)	Reel Size(D)	Packing Minimum	MSL
SOT23-3	8.0 ± 0.1 mm	4.0 ± 0.1 mm	4.0 ± 0.1 mm	180 ± 1 mm	3000pcs	3

For further information about iSentek's Magnetic Sensors, please send an email to [sales@isentek.com](mailto:sales@isentek.com) visit our website at [www.isentek.com](http://www.isentek.com).

## 7. Legal disclaimer

### 7.1. Warranty and Liability Disclaimer

iSentek Inc. guarantees the information in this datasheet. It is assumed that the specification is accurate and reliable. However, iSentek Inc. makes no warranties or claims regarding the accuracy or completeness of this information and takes no responsibility for the use of the information, nor does it convey any license under its patent rights or the rights of third parties. iSentek Inc. shall not be liable for any consequential, incidental, indirect, or punitive damages (including, but not limited to, profit loss, business interruption, and further expenses related to the removal, replacement, or rework of any products).

### 7.2. Application Disclaimer

iSentek's products are unsuitable for life-critical and safety-critical applications. For the use of its products in such applications, iSentek disclaims all liability. The customer agrees to indemnify and hold iSentek harmless from and against all liabilities and losses.

### 7.3. Disclaimer Regarding Changes

iSentek reserves the right to modify the contents of this datasheet, including specifications and descriptions, at any time and without prior notice. This document supersedes all previously issued information.

### Revision History

Revision Version	Date	Description
1.0	March 28 <sup>th</sup> , 2025	Initial release
1.1	August 21 <sup>st</sup> , 2025	Edited VDD up to 5.5 V; edited bandwidth up to 30 kHz; edited IST8812-B and -C sensitivity and other specifications (Page 8, 9, 10)