

IST8508

3D Micro Power Omnipolar AMR/Hall-effect Sensor Switch

Datasheet

Table of Contents

1. GENERAL DESCRIPTION	4
2. PIN CONFIGURATION, APPLICATION CIRCUIT, BLOCK DIAGRAM, AND PACKAGE DIMENSION	5
2.1. Pin Configuration	5
2.2. Application Circuit	5
2.3. Block Diagram.....	6
2.4. Package Dimensions and Pin Description (SOT23-3L)	6
3. FUNCTIONAL DESCRIPTIONS	7
3.1. Low Average Power	7
3.2. Chopper-Stabilization Technique.....	7
3.3. Magnetic Field Detection Mechanism	8
3.4. Operation.....	8
3.5. Programmability:	9
4. ELECTRICAL SPECIFICATIONS.....	9
4.1. Absolute Maximum Ratings.....	9
4.2. Recommended Operating Conditions	9
4.3. Electrical Specifications.....	10
4.4. Magnetic Specifications of XY axis.....	11
4.5. Magnetic Specifications of Z axis.....	11
4.6. Typical Characteristics of XY Axes	11
4.7. Typical Characteristics of Z Axis.....	12
4.8. Typical Characteristics of Average Current	12
5. MARKING INFORMATION.....	12
6. PACKING INFORMATION.....	13
7. ORDERING INFORMATION.....	13

8. LEGAL DISCLAIMER..... 14

8.1. Warranty and Liability Disclaimer 14

8.2. Application Disclaimer 14

8.3. Disclaimer Regarding Changes 14

1. General Description

IST8508 is a high-speed, 3D omni-polar magnetic switch IC designed for industrial-grade magnetic sensing applications such as flow metering, tamper detection, and non-contact position sensing. It integrates advanced AMR (Anisotropic Magnetoresistive) and Hall-effect sensors to detect magnetic fields in all three spatial axes (X, Y, and Z).

The IST8508 supports programmable magnetic operate and release thresholds as low as ± 13 G, offering high sensitivity and low hysteresis for reliable detection. With a maximum magnetic sampling rate of 24 kHz, the device is well suited for high-speed applications such as turbine flowmeters and rotating machinery.

Additional features include one-time programmable (OTP) settings for output polarity, data rate, threshold levels, and axis selection. The device is housed in a compact SOT23-3 package, operates from -40°C to 85°C , and requires only a single MLCC capacitor for operation, minimizing overall system BOM and footprint.

Features

- 3D omnipolar magnetic detection
- High-speed switching up to 24 kHz
- Active-low digital output with level-triggered logic
- Low hysteresis and programmable BOP/BRP thresholds
- Wide input voltage range: 2.5 V to 5.5 V
- Push-pull or open-drain output configuration
- Inverting output mode available
- Chopper-stabilized amplifiers for low offset and thermal drift
- Minimal external components required (single MLCC capacitor)
- Operating temperature: -40°C to 85°C

Applications

- **Water and gas meter flow sensing**
- **Tamper detection** in smart electricity meters
- **Non-contact position and lid detection** for industrial enclosures
- **Proximity sensing** in industrial automation systems
- **Magnetic switch replacement** for reed sensors in harsh environments
- **Speed or rotation detection** in motor control and metering systems
- **Magnetic event detection** in industrial safety and control panels

2. Pin Configuration, Application Circuit, Block Diagram, and Package

Dimension

SOT23-3 (Top View)

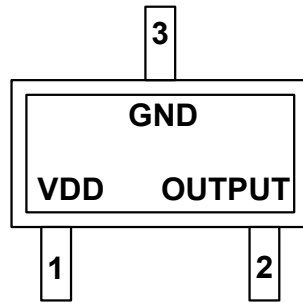

Figure 1. Pin configuration

2.1. Pin Configuration

Pin Name	Pin No.	Pin Function
VDD	1	Power Supply Input
GND	3	Ground
OUTPUT	2	Output Pin

2.2. Application Circuit

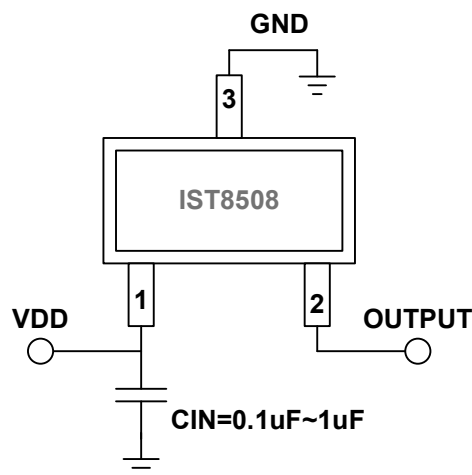

Figure 2. Application circuit

2.3. Block Diagram

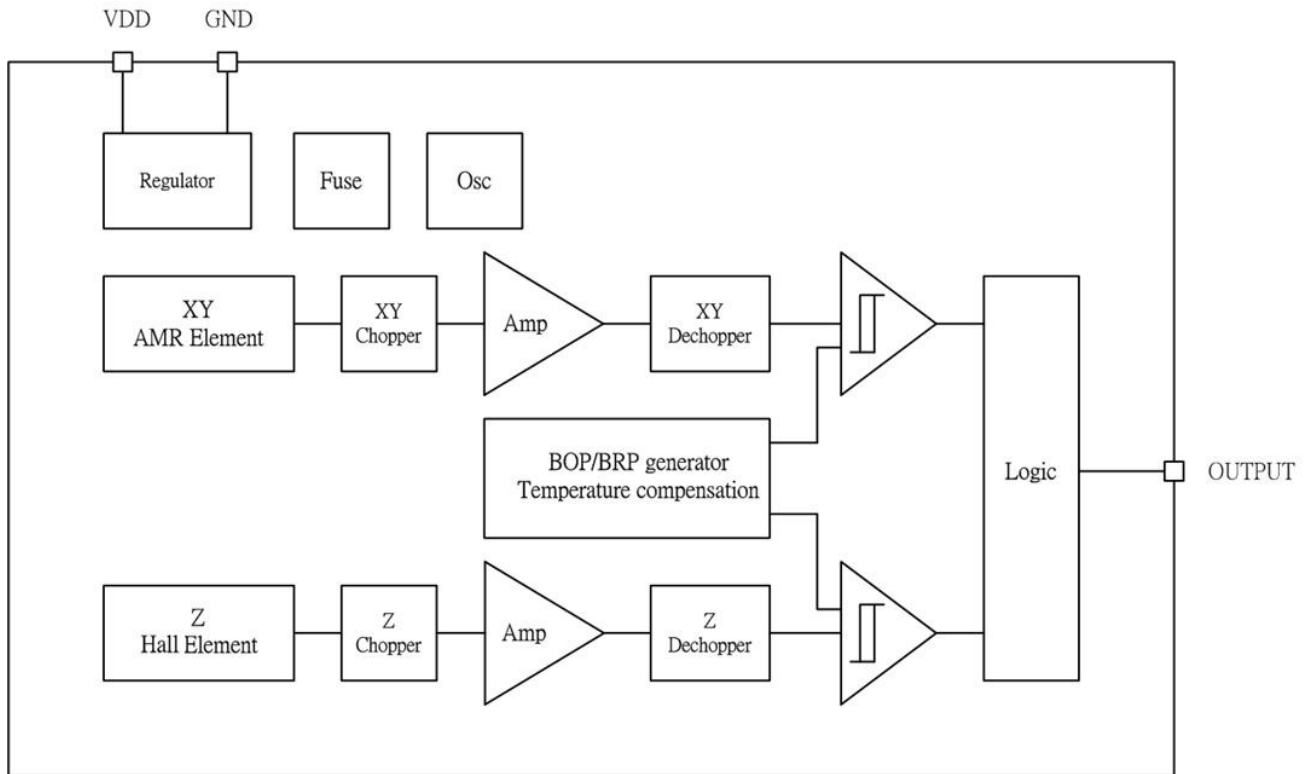
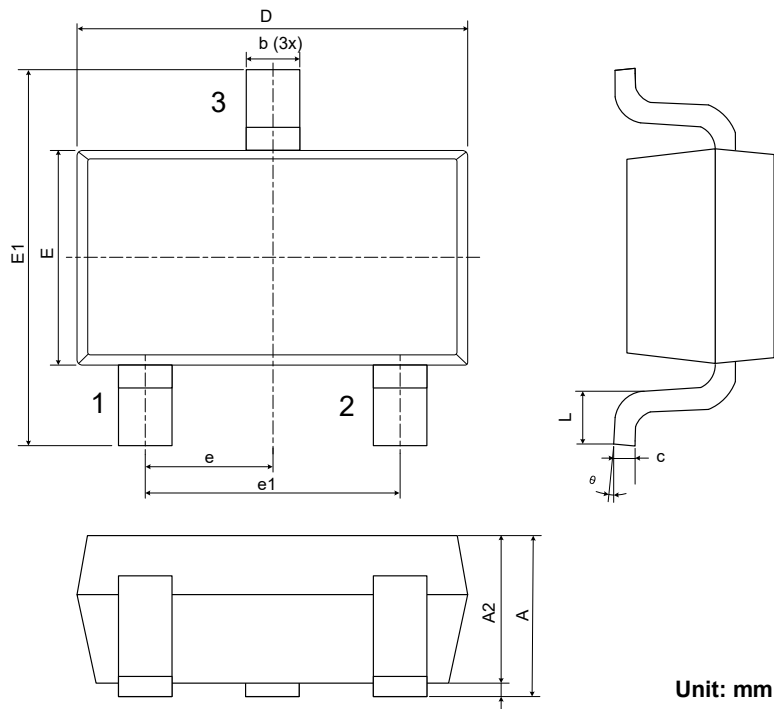

Figure 3. Block Diagram.

2.4. Package Dimensions and Pin Description (SOT23-3L)



Unit: mm

Figure 4. Package Dimension

Symbol	Dimensions In Millimeters			Dimensions In Inches		
	Min.	Typ.	Max.	Min.	Typ.	Max.
A	1.050	1.15	1.250	0.041	0.045	0.049
A1	0.000	0.050	0.100	0.000	0.002	0.004
A2	1.050	1.100	1.150	0.041	0.043	0.045
b	0.300	0.400	0.500	0.012	0.016	0.020
c	0.100	0.150	0.200	0.004	0.006	0.008
D	2.820	2.920	3.020	0.111	0.115	0.119
E	1.500	1.600	1.700	0.059	0.063	0.067
E1	2.650	2.800	2.950	0.104	0.110	0.116
e1	1.800	1.900	2.000	0.071	0.075	0.079
e	0.950 REF			0.037 REF		
L	0.300	0.450	0.600	0.012	0.018	0.024
θ	0°	4°	8°	0°	4°	8°

3. Functional Descriptions

3.1. Low Average Power

To reduce power consumption, the IST8508 employs a duty-cycled architecture. The internal timing circuitry activates the sensing and signal processing circuits for **140 μ s** every **100 ms** period, after which the device enters a low-power sleep mode.

During the active window, the sensing circuitry stabilizes and samples the magnetic field. The output is then latched and **retained during the sleep phase**, maintaining the most recent logic state until the next sampling cycle.

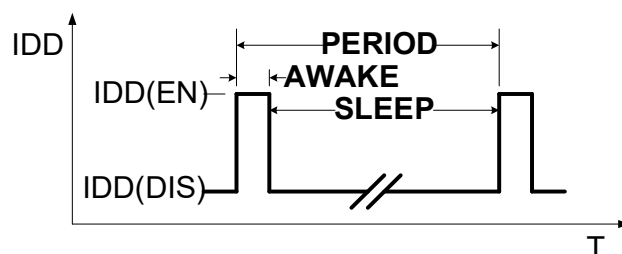

3.2. Chopper-Stabilization Technique

IST8508 uses a chopper-stabilization technique to actively cancel offset voltages introduced by the signal chain and Hall sensor. This dynamic offset cancellation, in conjunction with on-chip trimming, ensures **stable and accurate magnetic thresholds** (BOP and BRP) across temperature and process variations. The result is improved sensitivity

symmetry and minimized drift.

3.3. Magnetic Field Detection Mechanism

The device supports **3D magnetic field detection** by combining two types of sensors:

- The **AMR sensor** detects magnetic fields in the lateral plane (X and Y axes).
- The **Hall-effect sensor** detects fields along the perpendicular Z axis.

This allows the IST8508 to respond to magnetic field components from any spatial direction, enabling flexible placement and robust performance in various application environments.

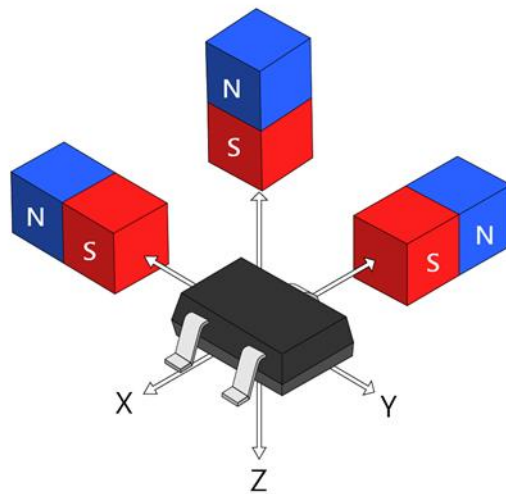

Figure 5. Magnetic field direction

3.4. Operation

The IST8508 supports flexible magnetic axis selection and can be programmed to respond to magnetic fields along: X only; Y only; Z only; X + Y; X + Z; Y + Z; X + Y + Z (XYZ all-axes mode)

The AMR sensor detects magnetic fields in the lateral (X and Y) directions, while the Hall-effect sensor measures the perpendicular (Z) direction. These responses are independent of each other and processed separately.

When XYZ mode is enabled, the outputs from each axis are digitized into single-bit signals and logically ORed to generate the final digital output. This ensures that the output asserts (goes low) when a magnetic field above threshold is detected on any of the selected axes.

Note that the AMR sensor's response in the XY plane is influenced by combined projections on both X and Y axes. Therefore, sensitivity may decrease if magnetic components are present on both axes simultaneously. The magnetic specifications in section 4.4 assume alignment along a single axis (either X or Y) for accurate threshold

reference.

3.5. Programmability:

IST8508 offers **one-time programmable (OTP)** configuration for several parameters, enabling tailored performance for specific applications. Programmable options include:

- Axis selection (X, Y, Z, or combinations)
- Output data rate (ODR)
- BOP/BRP
- Temperature compensation codes
- Output mode selection (push-pull or open-drain)
- Output polarity (inverting or non-inverting)

This programmability allows for easy integration into systems with varied magnetic profiles and timing requirements, supporting both static and high-speed applications up to 24 kHz.

4. Electrical Specifications

4.1. Absolute Maximum Ratings

Parameter		Symbol	Rating	Unit
VDD to GND		V_{DD}	-0.3 to 6	V
Magnetic Flux Density		B	Unlimited	
Storage Temperature Range		T_S	-55 to 150	°C
Operating Junction Temperature Range		T_J	-40 to 150	°C
Package Power Dissipation	SOT23-3L	PD	180	mW

4.2. Recommended Operating Conditions

Parameter	Symbol	Conditions	Rating	Unit
Supply Voltage	V_{DD}	Operating	2.5 – 5.5	V
Operating Temperature Range	T_A	Operating	-40 – 85	°C

4.3. Electrical Specifications

(Unless otherwise noted, typical values are at $T_A = 25\text{ }^\circ\text{C}$, $V_{DD} = 3\text{ V}$)

Symbol	Parameter	Conditions	Min.	Typ.	Max.	Unit
V_{OH}	Output Off Voltage (High side)	$I_{OUT} = 1\text{ mA}$	$V_{DD} - 0.3$	$V_{DD} - 0.1$	$V_{DD} + 0.3$	V
V_{OL}	Output Off Voltage (Low side)	$I_{OUT} = -1\text{ mA}$	-0.3	0.1	0.3	V
I_{OFF}	Output Leakage Current	$V_{OUT} = 4.5\text{ V}$, Output off	-	< 0.1	1.0	μA
$I_{DD}(EN)$	Supply Current (ODR = 10 Hz)	Chip enabled, $T_A = 25\text{ }^\circ\text{C}$, $V_{DD} = 3.3\text{ V}$	-	2.5	3	mA
$I_{DD}(EN)$		Chip enabled, $T_A = -40 - 85\text{ }^\circ\text{C}$, $V_{DD} = 2.5 - 5.5\text{ V}$	-	2.5	3	mA
$I_{DD}(DIS)$		Chip disable, $T_A = 25\text{ }^\circ\text{C}$, $V_{DD} = 3.3\text{ V}$	-	2.0	2.5	μA
$I_{DD}(DIS)$		Chip disable, $T_A = -40 - 85\text{ }^\circ\text{C}$, $V_{DD} = 2.5 - 5.5\text{ V}$	-	2.0	9.0	μA
I_{DD} (AVG)		Average supply current, $T_A = 25\text{ }^\circ\text{C}$, $V_{DD} = 3.3\text{ V}$	-	5.7	7	μA
I_{DD} (AVG)		Average supply current, $T_A = -40 - 85\text{ }^\circ\text{C}$, $V_{DD} = 2.5 - 5.5\text{ V}$	-	5.7	12	μA
$I_{DD}(NS)$		Supply Current (No Sleep) (ODR = 7 kHz, BW = 3.5 kHz)	$T_A = 25\text{ }^\circ\text{C}$, $V_{DD} = 3.3\text{ V}$	-	2.5	-
T_{awake}	Awake Time	-	-	140	200	μs
T_{period}	Period	-	-	100	150	ms
D.C.	Duty Cycle	-	-	0.14	-	%
f_s	Magnetic Sampling Rate (Max.)	Continuous sampling mode			24	kHz

4.4. Magnetic Specifications of XY axis

Symbol	Parameter	Min.	Typ.	Max.	Unit
BOPS	Operate Point	13	18	30	G
BOPN		-30	-18	-13	
BRPS	Release Point	8	14	20	
BRPN		-20	-14	-8	
BHY	Hysteresis	-	4	-	

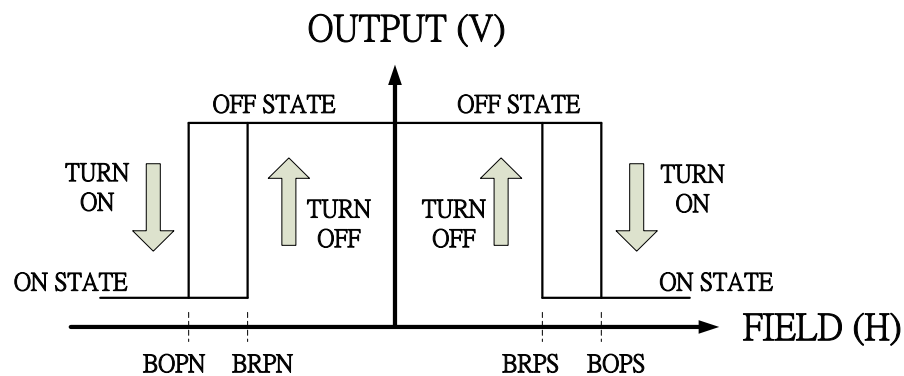

4.5. Magnetic Specifications of Z axis

Symbol	Parameter	Min.	Typ.	Max.	Unit
BOPS (south pole to brand side)	Operate Point	13	16	28	Gauss
BOPN (north pole to brand side)		-28	-16	-13	
BRPS (south pole to brand side)	Release Point	8	12	18	
BRPN (north pole to brand side)		-18	-12	-8	
BHY (BOPX-BRPX)	Hysteresis	-	4	-	

4.6. Typical Characteristics of XY Axes

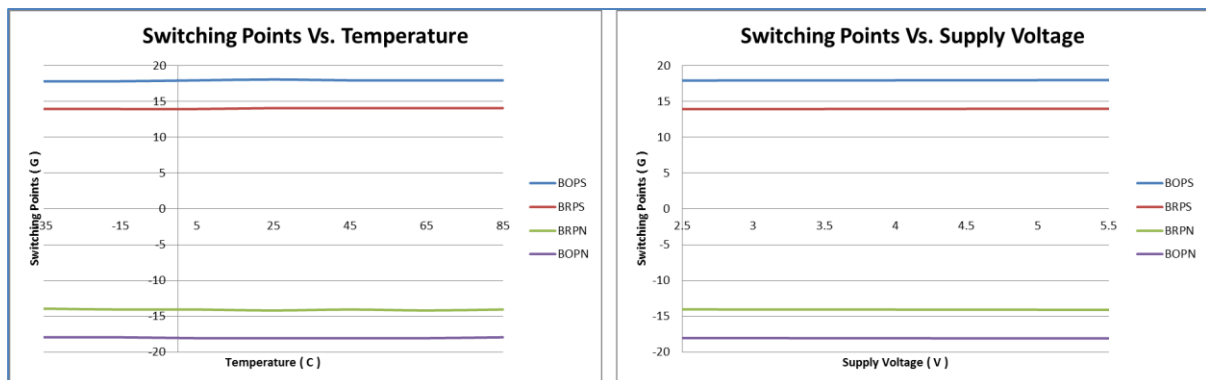

4.7. Typical Characteristics of Z Axis

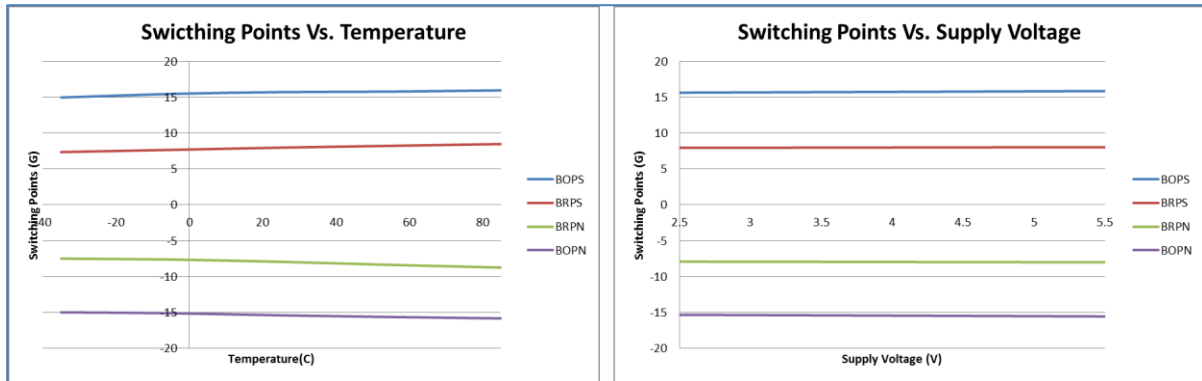

4.8. Typical Characteristics of Average Current

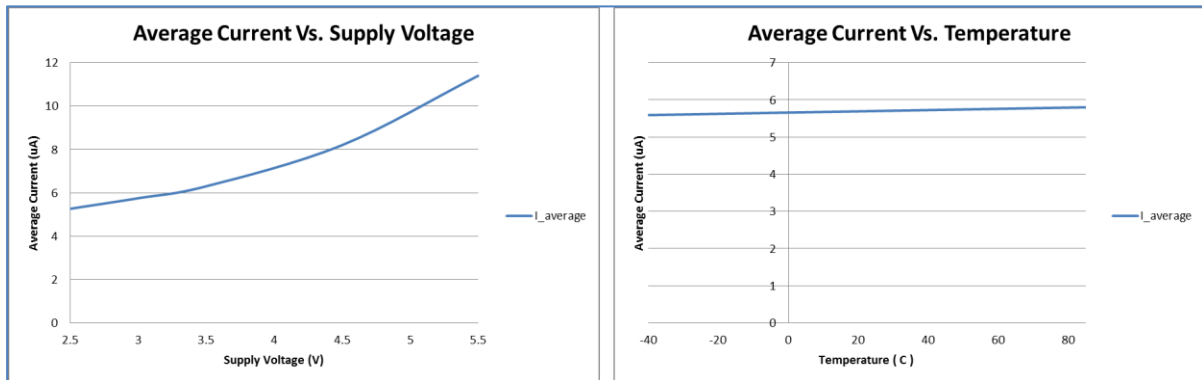

5. Marking Information

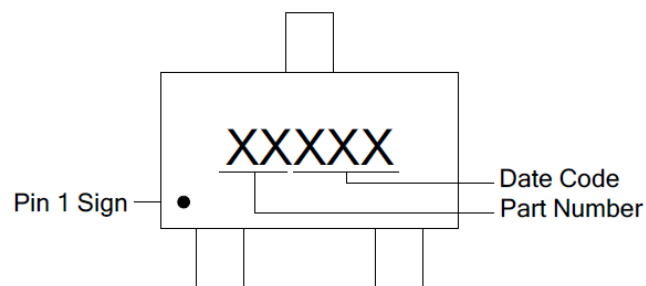

6. Packing Information

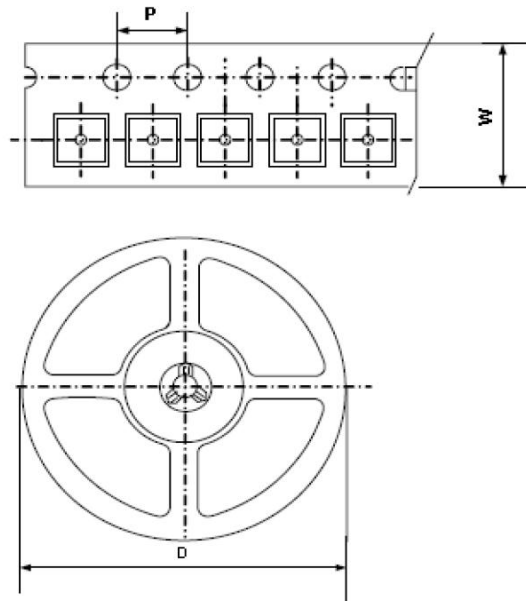

Reel tape with round hole facing up, Pin 1 positioned at the bottom left.

Moisture Sensitivity Level (MSL): 3

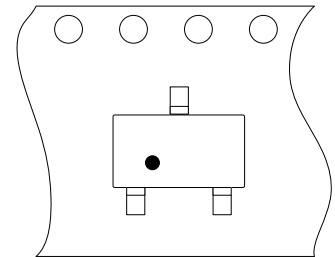

Package Type	Carrier Width (W)	Pitch (P)	Reel Size (D)	Packaging Minimum
SOT23-3	8.0 ± 0.1 mm	4.0 ± 0.1 mm	180 ± 1 mm	Tape and Reel: 3k pcs per reel

Note: Carrier Tape Dimension, Reel Size and Packing Minimum.

7. Ordering Information

Part Number	Package Type	Packing Quantity	B _{OPS} (Gauss)	B _{RPS} (Gauss)	Temp. (°C)	Eco Plan	Lead
IST8508	SOT23-3	7-in reel 3000 pcs/reel	±15 - ±28	±8 - ±18	-40 - 85	Green	Cu

For more information on iSentek's magnetic sensors, please send an email to sales@isentek.com or visit our website at www.isentek.com.

US Patent 9297863, Taiwan Patents I437249, I420128, I463160, and I710215 apply to our magnetic sensor technology described.

8. Legal Disclaimer

8.1. Warranty and Liability Disclaimer

iSentek Inc. guarantees the information in this datasheet. It is assumed that the specification is accurate and reliable. However, iSentek Inc. makes no warranties or claims regarding the accuracy or completeness of this information and takes no responsibility for the use of the information, nor does it convey any license under its patent rights or the rights of third parties.

iSentek Inc. shall not be liable for any consequential, incidental, indirect, or punitive damages (including, but not limited to, profit loss, business interruption, and further expenses related to the removal, replacement, or rework of any products).

8.2. Application Disclaimer

iSentek's products are unsuitable for life-critical and safety-critical applications. For the use of its products in such applications, iSentek disclaims all liability. The customer agrees to indemnify and hold iSentek harmless from and against all liabilities and losses.

8.3. Disclaimer Regarding Changes

iSentek reserves the right to modify the contents of this datasheet, including specifications and descriptions, at any time and without prior notice. This document supersedes all previously issued information.

Revision History

Revision Version	Date	Description
1.0	July 5 th , 2021	Initial release
1.1	July 26 th , 2023	Edited table 4.3, BW = 3.5 KHz (Page 10)
1.2	December 1 st , 2025	Added Packing Information (Page 13), edited BOPs/BRPs on the XY axis (Page 11)