

IST8801

Digital Linear Hall Sensor

Datasheet

Table of Contents

1. GENERAL DESCRIPTION	3
2. BLOCK DIAGRAM, PACKAGE DIMENSION, MAGNETIC FIELD DIRECTION AND APPLICATION CIRCUIT	4
2.1. Block diagram	4
2.2. Package Dimensions and Hall Element Locations	5
2.3. Pin Configurations and Functions	6
2.4. Magnetic Field Direction.....	7
2.5. Application Circuit.....	7
3. ELECTRICAL SPECIFICATIONS.....	8
3.1. Absolute Maximum Ratings.....	8
3.2. Recommended Operating Conditions	8
3.3. Electrical Specifications	8
3.4. Magnetic Sensor Specifications.....	10
3.5. Power On Reset (POR) Specifications	10
4. PACKING INFORMATION	11
5. ORDERING INFORMATION.....	11
6. LEGAL DISCLAIMER.....	11
6.1. Warranty and Liability Disclaimer	11
6.2. Application Disclaimer.....	11
6.3. Disclaimer Regarding Changes.....	12

1. General Description

iSentek IST8801 is a digital linear hall sensor to measure magnetic flux intensity. It is an integrated chip with magnetic sensors and a control ASIC with a 16-bit ADC output. IST8801 provides an I²C digital output with a fast mode up to 400 kHz. Wide dynamic range operation, high resolution, and compact form factor features make it the best candidate for handheld, wearable, and IoT devices.

Features

- Single chip linear hall sensor with digital output
- Compact form factor, 1.33 x 1.33 x 0.53 mm³, 9-pin WLCSP-BGA package
- I²C slave, Fast Mode up to 400 kHz
- High dynamic range of maximum ± 40.96 mT
- High resolution of maximum 0.3125 μ T/LSB (16-bit setting with 10.24 mT dynamic range)
- High output data rate of maximum 500 Hz
- 8~16-bit adjustable data output
- Operation Temperature -40 ~ 85 °C
- Built-in oscillator for internal clock source
- Power on Reset circuit
- RoHS, HF and TSCA compliant

Applications

Magnetometer for external magnet detection

Lid opening angle detection

Displacement detection

VCM modules

2. Block Diagram, Package Dimension, Magnetic Field Direction and Application Circuit

Application Circuit

2.1. Block diagram

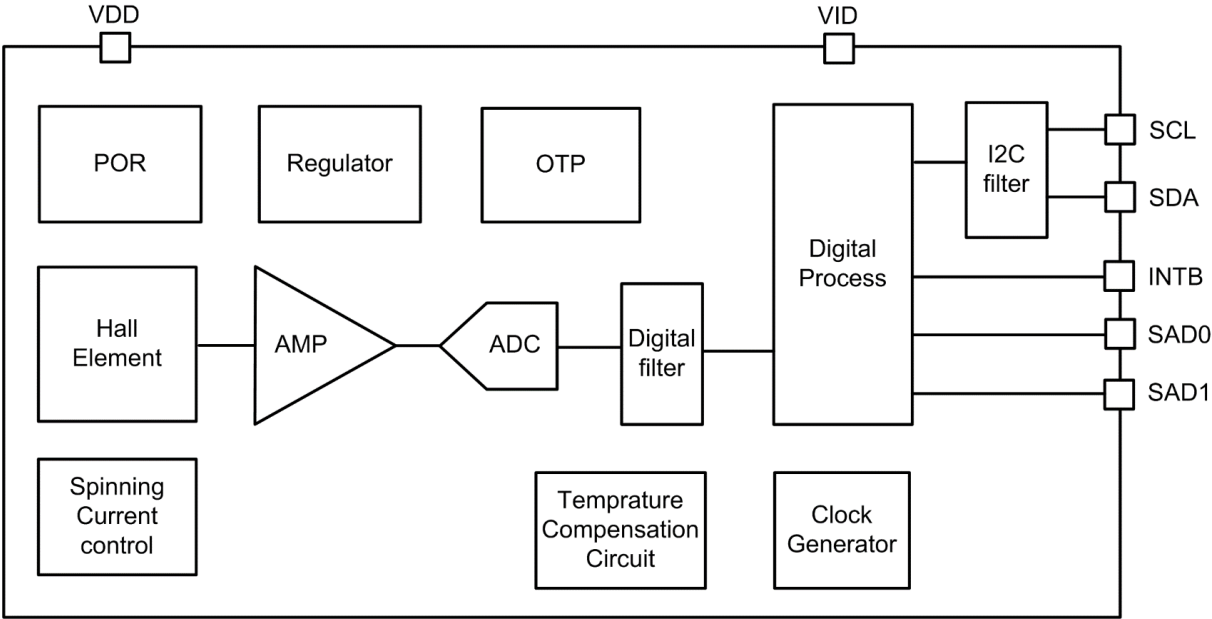

Figure 1. Block Diagram

2.2. Package Dimensions and Hall Element Locations

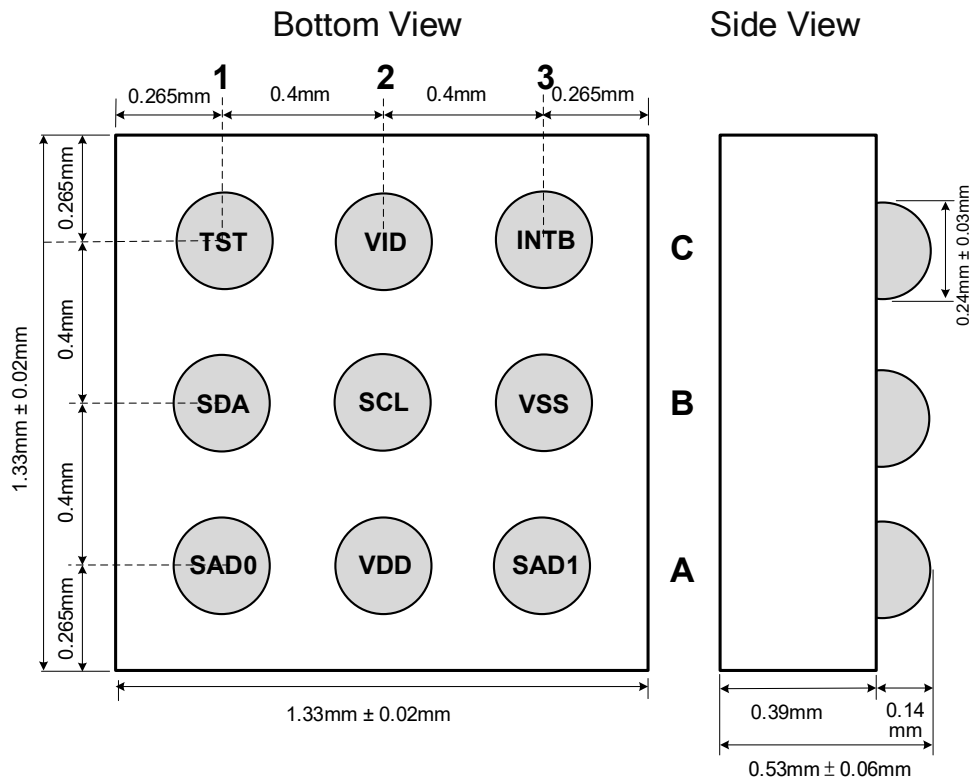

Figure 2. Package Dimensions

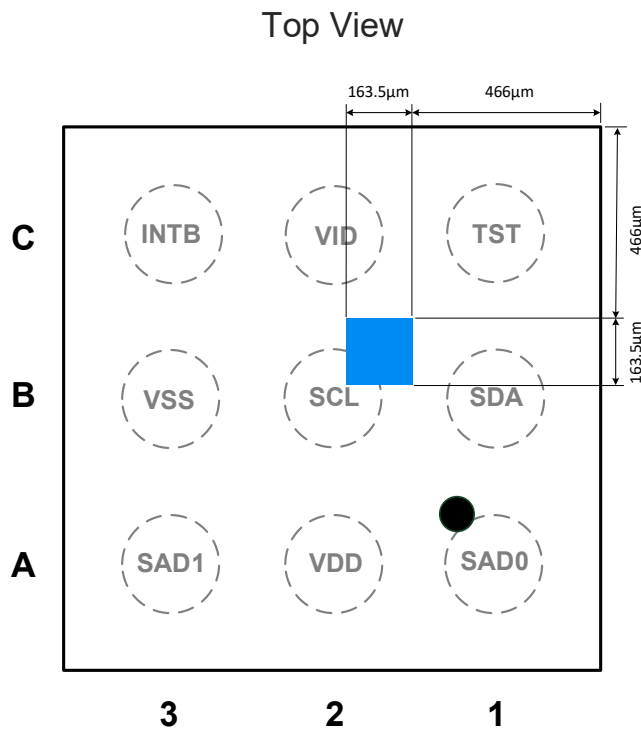

Figure 3. Hall Element Locations

2.3. Pin Configurations and Functions

Product code X₁X₂X₃X₄

Date code X₅X₆X₇●

X₁X₂X₃X₄: Product code

X₅: Year

X₆X₇: Week

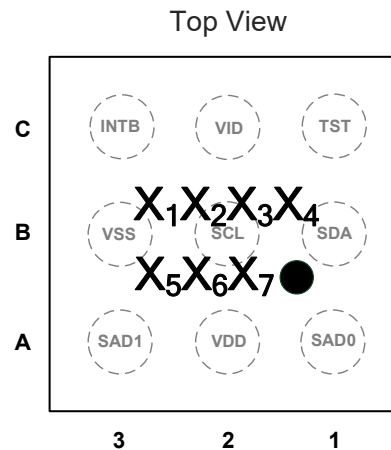

Pin No	Pin Name	I/O type	Function
A1	SAD0	I	I ² C slave address selection, connect to GND or VDD. Internally pull-low when floating
A2	VDD	Supply	Power supply voltage: 1.8 ~ 3.6 V
A3	SAD1	I	I ² C slave address selection, connect to GND or VDD. Internally pull-low when floating.
B1	SDA	I/O	I ² C data, should be connected to VID with 1.5 kΩ resistor
B2	SCL	I	I ² C clock, should be connected to VID with 1.5 kΩ resistor
B3	VSS	Supply	Should be connected to Ground
C1	TST	I/O	Keep it floating or connect it to VDD/GND ^{*1}
C2	VID	Supply	Digital power supply voltage: 1.65~VDD.
C3	INTB	O	When detected magnetic flux density meets specific threshold level, INTB become low level unless user clear it manually via PERSINT[0]. Internally pull-high when floating.

^{*1}TSTCNTL register (0x76H) need to be set to 0x04H when TST pin is connected to VDD/GND.

2.4. Magnetic Field Direction

The measurement data increases as the magnetic flux density increases in the arrow directions

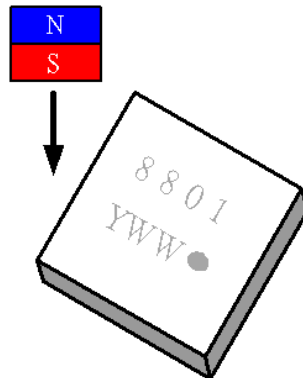

2.5. Application Circuit

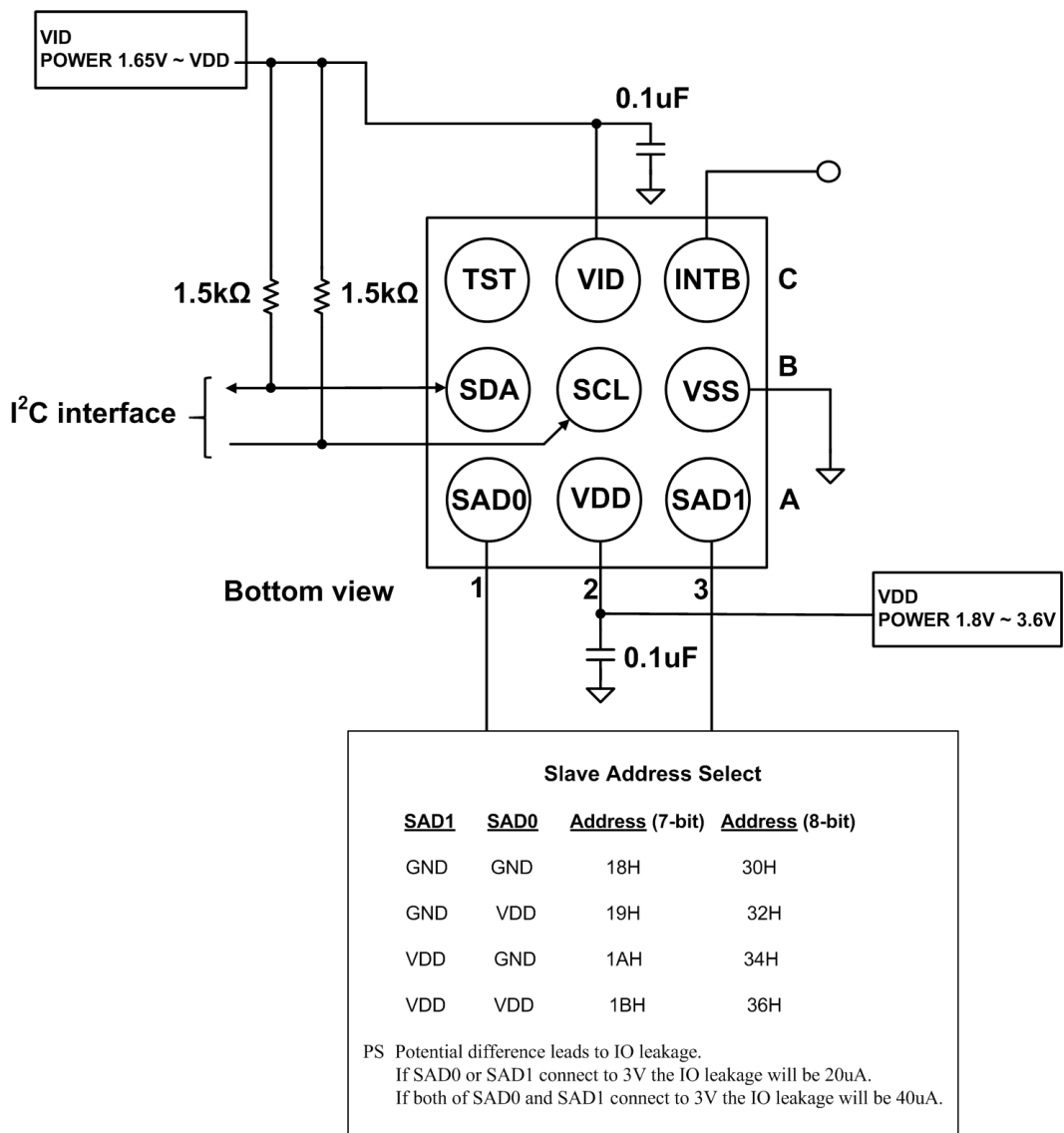

Figure 4. Application Circuit

3. Electrical Specifications

3.1. Absolute Maximum Ratings

Parameter	Symbol	Limits	Unit
Storage Temperature	TSTG	-40 to +150	°C
Power Supply Voltage (VDD)	VDD	-0.3 to +3.8	V
Power Supply Voltage (VID)	VID	-0.3 to +3.8	V
Digital Input Voltage	VIN	-0.3 to VDD + 0.3	V
Electrostatic Discharge Voltage* ¹	VESD_HBM	-2000 to 2000	V
Electrostatic Discharge Voltage* ³	VESD_CDM	-1000 to 1000	V
Reflow Classification	JESD22-A113 with 260°C Peak Temperature		

If the device is used in conditions exceeding these limits, it may malfunction permanently. Performance cannot be assured when these limits are exceeded.

1. Human Body Model (HBM)
2. Charge Device Model (CDM)

3.2. Recommended Operating Conditions

Parameter	Symbol	Min.	Typ.	Max.	Unit
Operating Temperature	TA	-40		+85	°C
Power Supply Voltage (VDD)	VDD	1.8	3.3	3.6	V
Power Supply Voltage (VID)	VID	1.65	1.8	3.6	V

3.3. Electrical Specifications

Operating conditions: TA = +25 °C; VDD = 3.0 V; VID = 3.0 V or 1.8 V; CAD0 = GND;

CAD1 = GND

Parameter	Symbol	Conditions	Min.	Typ.	Max	Unit
Current Consumption	IDD	50 sample per second* ¹		180		µA
		500 sample per second* ¹		600		
		50 sample per second* ²		450		
		500 sample per second* ²		3300		
Suspend Current	ISUP			2		µA
Standby Mode Current	ISTB			100		µA

Output Data Rate	ODR				500	Hz
Input Low Voltage (For SCL, SDA)	VIL		0		VID *30%	V
Input High Voltage (For SCL, SDA)	VIH		VID *70%			V
Output Low Voltage	VOL	IOL= +4mA	0		VID *20%	V
Output High Voltage	VOH	IOH= -100uA (Except SCL and SDA)	VID *80%		VID	V

*1 Current consumption in Continuous Measurement Mode, OSR = 4

*1 Current consumption in Continuous Measurement Mode, OSR = 32

3.4. Magnetic Sensor Specifications

Operating conditions: TA = 25 °C; VDD = 3.0 V; VID = 1.8 V.

Parameter	Symbol	Condition	Low	Mid.	High	Unit
Dynamic Range* ¹	DR		±10.24	±20.48	±40.96	mT
Resolution* ¹	RES	16-bit setting* ¹	0.3125	0.625	1.25	μT/LSB

*¹CNTL2(0x0D) controls dynamic range setting and resolution setting.

3.5. Power On Reset (POR) Specifications

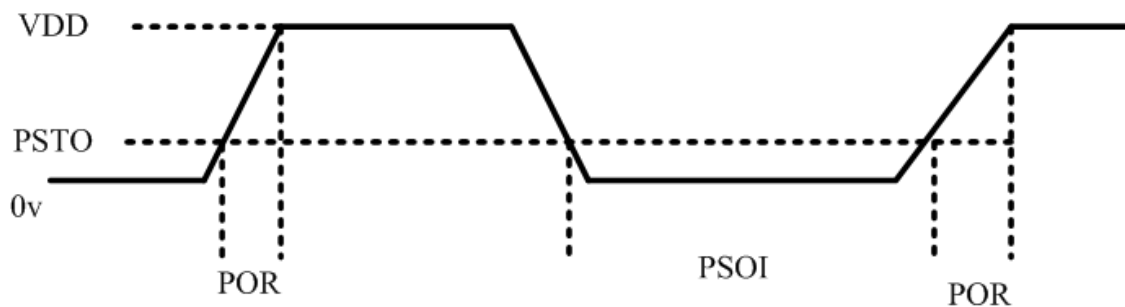

PSTO: Power Supply Turn Off voltage
 PSOI: Power Supply Turn Off Interval
 POR: Power On Reset

PSTO: max=0.1 volt
 PSOI: min=30ms
 POR: max:50ms

When POR circuit detects a rise of VDD voltage, it resets all internal circuits and initializes all registers. After reset, IST8801 transits to Standby Mode.

4. Packing Information

Reel tape with round hole facing up, with Pin 1 positioned at the top left.

Moisture Sensitivity Level (MSL): 1

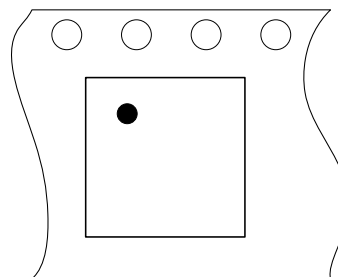

5. Ordering Information

Order Number	Package Type	Packaging	Temperature Range	Marking Information
IST8801	WLCSP – 9 pins	Tape and Reel: 3k pieces per reel	-40 to +85°C	X ₁ X ₂ X ₃ X ₄ X ₅ X ₆ X ₇ ● X ₁ X ₂ X ₃ X ₄ : Product code X ₅ : Year X ₆ X ₇ : Week

For more information on iSentek’s magnetic sensors, please send an email to sales@isentek.com or visit our website at www.isentek.com.

6. Legal Disclaimer

6.1. Warranty and Liability Disclaimer

iSentek Inc. guarantees the information in this datasheet. It is assumed that the specification is accurate and reliable. However, iSentek Inc. makes no warranties or claims regarding the accuracy or completeness of this information and takes no responsibility for the use of the information, nor does it convey any license under its patent rights or the rights of third parties. iSentek Inc. shall not be liable for any consequential, incidental, indirect, or punitive damages (including, but not limited to, profit loss, business interruption, and further expenses related to the removal, replacement, or rework of any products).

6.2. Application Disclaimer

iSentek's products are unsuitable for life-critical and safety-critical applications. For the use of its products in such applications, iSentek disclaims all liability. The customer agrees to indemnify and hold iSentek harmless from and against all liabilities and losses.

6.3. Disclaimer Regarding Changes

iSentek reserves the right to modify the contents of this datasheet, including specifications and descriptions, at any time and without prior notice. This document supersedes all previously issued information.

Revision History

Revision Version	Date	Description
1.2	March 2 nd , 2021	Initial release
1.3	Dec 25 th , 2024	Edited figure 2. Package Dimensions (Page 6) Added MSL and Packing Information (Page 25)